

Demo Board Test Report for LD5530

--- 65W (19V, 3.42A) Adapter

Tested by	Reviewed by	Approved by
Joy	Yichuan	Ming

Total pages	Revision	Date
25	A	2013/05/16

Contents

I. SCHEMATIC	3
II. BOM.....	4
III. EXECUTIVE SUMMARY.....	5
IV. GERBER FILE.....	24
V. TRANSFORMER SPEC	26

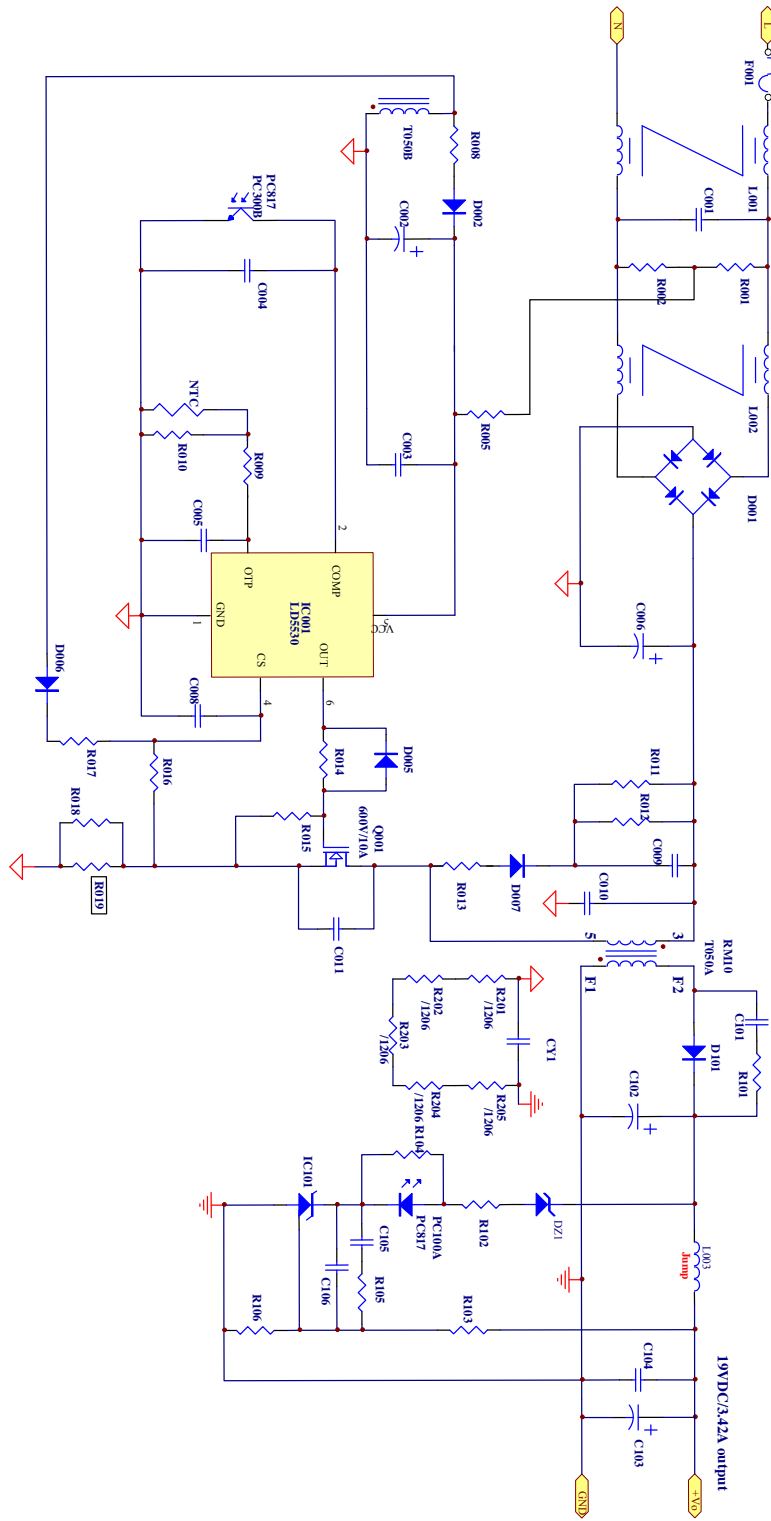
I. Schematic

II. BOM

P/N	Component Value	Note
R001	2.2MΩ, 1206	
R002	2.2MΩ, 1206	
R004	NA	
R005	0Ω, 1206	
R008	0Ω, 0805	
R009	51K, 0805	
R010	51K, 0805	
R011	200KΩ, 1206	
R012	200KΩ, 1206	
R013	10Ω, 1206	
R014	51Ω, 0805	
R015	100KΩ, 0805	
R016	820Ω, 0805	
R017	91KΩ, 0805	
R018	NA	
R019	0.33/1W	
R101	51Ω, 1206	
R102	150Ω, 0805	
R103	62KΩ, 0805	
R104	3K6Ω, 0805	
R105	1KΩ, 0805	
R106	4.3KΩ, 0805	
R201	NA	
R202	NA	
R203	NA	
R204	NA	
R205	NA	
L001	LD design	
L002	LD design	
L003	Jump	

P/N	Component Value	Note
C001	0.33μF	X-cap
C002	4.7μF, 50V	
C003	0.1μF, 50V, 0805	
C004	4.7nF, 16V, 0805	
C005	470pF, 16V, 0805	
C006	120uF, 400V	
C008	100pF, 16V, 0805	
C009	1000pF, 500V, 1206	
C010	1000pF, 500V, 1206	
C011	NA	
C101	330pF, 500V, 1206	
C102	680μF, 35V	
C103	680μF, 35V	
C104	0.1uF, 25V	
C105	47nF, 16V, 0805	
C106	NA	
CY1	470pF	Y-cap
D001	KBP406G	
D002	1N4007	PANJIT
D005	4148	
D006	BAV103	
D007	PS1010R	PANJIT
D101	SB20150FCT	PANJIT
ZD1	5.6V Zener	
IC001	LD5530	SOT-26
IC101	431(TI)	Vref=1.25V
PC300	LTV-817B	Lite-ON
Q001	10N60	Niko-Sem
F1	250V, 2A	
T050A	LD design	RM10

III. EXECUTIVE SUMMARY	6
1. INPUT VOLTAGE & FREQUENCY	7
2. OUTPUT LOADS.....	7
3. GREEN MODE POWER CONSUMPTION	7
4. TOTAL REGULATION	8
5. TURN ON DELAY TIME	9
6. HOLDUP TIME	10
7. OVER CURRENT PROTECTION.....	11
8. OVER VOLTAGE PROTECTION	12
9. OUTPUT SHORT PROTECTION.....	13
10. EFFICIENCY TEST	14
11. POWER COMPONENT STRESS VOLTAGE	15
12. THERMAL TEST.....	17

III. EXECUTIVE SUMMARY

Office	Taipei
Model Name	LD5530-DemoBoard#01
Version	01
IC	LD5530

TEST	Result	Comments
Green Mode Power Consumption	PASS	
Line Regulation	PASS	
Load Regulation	PASS	
Turn On Delay Time	PASS	
Holdup Time	PASS	
Over Current Protection	PASS	
Over Voltage Protection	PASS	
Output Short Protection	PASS	
Efficiency Test	PASS	
Stress Voltage Test	PASS	
Thermal Test	PASS	

1. Input Voltage & Frequency

The unit shall be capable of operating as a universal AC input power supply accepting AC inputs. The power supply shall operate between the following voltages (from 90V to 264V). The supply will be designed to operate for a Table 1.

	Minimum	Normal	Maximum
Input Voltage	90Vac	110Vac	264Vac
Frequency	47HZ	60HZ	63HZ

Table 1

2. Output Loads

The line and load regulation for each of the outputs are shown in Table. 2.

Parameter	Output Voltage			Output Current	
	Minimum	Typical	Maximum	Minimum	Maximum
+19V	/	19V	/	0A	3.42A
Line Regulation	-1%	/	+1%	/	3.42A
Load Regulation	-2%	/	+2%	0A	3.42A

Table 2

3. Green Mode Power Consumption

The input power of power supply shall remain **less than 300mW** under output at no load condition.

Test Condition:

Input: 90Vac/115Vac/230Vac/264Vac (60Hz)

Output: +19V

Ambient Temperature: 25°C

Burn-In 20mintues

Test Result: PASS

Vin(Vac)	Pout(W)	Pin(mW)
90	No Load	42.29
115	No Load	45.25
230	No Load	72.63
264	No Load	82.93

Table 3-1.

	90Vac	115Vac	230Vac	264Vac
Pout	Pin(W)	Pin(W)	Pin(W)	Pin(W)
100mW	179.7m	181.6m	205.8m	217.4m
200mW	280.8m	281.7m	304.7m	318m
250mW	346.2m	347.4m	375.6m	385.2m
500mW	645.4m	644.2m	672.1m	685.6m
1W	1.239	1.23	1.264	1.284

Table 3-2.

4. Total Regulation

Line regulation is defined to be the percent change in output voltage versus the nominal output voltage due to a change in AC input. The supply shall maintain the specified regulation throughout its specified operating range. Line regulation is measured at Min. Nominal and Max input voltages.

Load regulation is defined to be the percent change in output voltage versus the nominal output voltage due to a change in load. The supply shall maintain the specified regulation throughout its specified operating range. Load regulation to be measured at Min. and Max output voltages.

Test Conditions:**Input: 90Vac/264Vac(60Hz)****Output: +19V=0A/3.42A****Ambient Temperature : 25°C**

AMB	Output	90Vac	264Vac
25	3.42A	18.896	18.869
DEG.C	0A	18.993	18.996
Reading		0.51%	0.67%
SPEC		±2%	

Table 4

5. Turn On Delay Time

Turn on delay time will be **less than 3 seconds** at full load. Turn on delay time is measured as the delay between input voltage being applied at 0° phase angle and when the outputs arrive within 10% of their operating value. Turn on delay time is measured using an input voltage of 90VAC(rms) and input frequency of 60Hz.

Test Conditions:

Input: 90Vac(60Hz)

Output: +19V=3.42A

Ambient Temperature : 25°C

Test Result: PASS

Input	T _{turn on delay}
90Vac	2.38s

Table 5

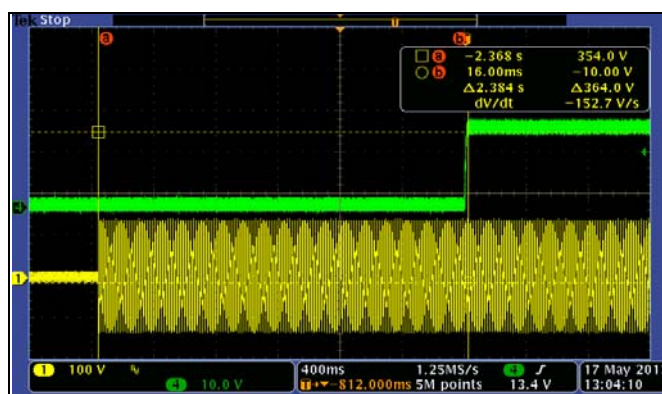

Turn on Time Test
 Vin: 90Vac/60Hz
 O/P: +19V=3.42A
 CH1: AC Input Voltage
 CH4: V_{O+19V}
 Reading: **1.69s**

Fig.1

6. Holdup Time

Holdup time refers to the time it takes for a loss of input voltage to propagate through the power supply and affect the output voltages. Holdup time spec must be met at 100Vac input line voltage and maintain minimum half AC cycle. Holdup time shall be measured by monitoring the output voltages and measuring the time it takes for the first affected output voltage to pass through the lower bound of the regulation threshold after input power to the converter is removed. The initial conditions of loading and input voltage are max load and minimum operational line input. The holdup time is measured by triggering an oscilloscope on the loss of input voltage while monitoring the conditions of the output voltages.

Test Conditions:

Input: 100Vac(50Hz)

Output: +19V=3.42A

Ambient Temperature : 25°C

Test Result: PASS

Input	T _{hold on}
100Vac	12.3ms

Table 6

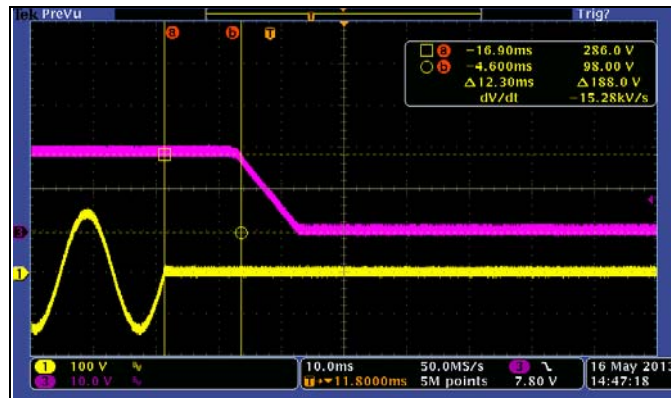

Hold-up Time Test
 Vin: 100Vac/50HZ
 O/P: Max Load
 CH1: AC Input Voltage
 CH4: V_{O+19V}
 Reading: **12.3ms**

Fig. 2

7. Over Current Protection

The supply shall be designed with appropriate output over current protection. This protection shall be activated in the event of a short or long-term condition during which one or more of the output current load increases such that the primary current exceeds a predetermined limit. The primary shall limit the total power without inflicting any damage to any internal supply components and shall be reversible pending removal of the cause of the condition and without any user intervention. This protection shall be activated **within 130% to 180%** of maximum load.

Test Condition:

Input: 90Vac/264Vac (60Hz)

Ambient Temperature: 25°C

Test Result: PASS

Input	OCP
90Vac	4.32A
264Vac	4.56A

Table 7

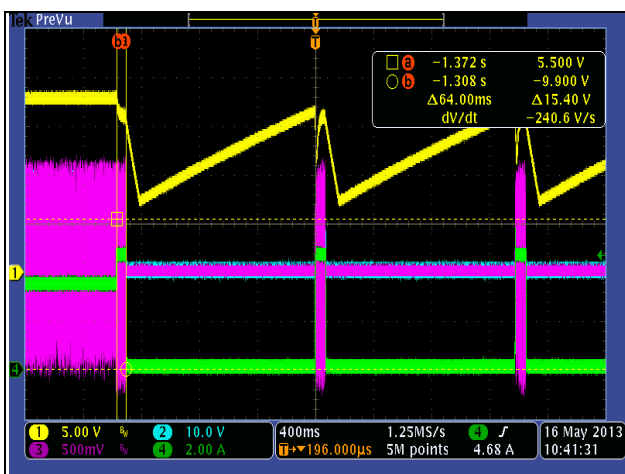

Fig.3

Over Current Protection
 Vin: 90Vac
 O/P : +19V=Max→OCP
 CH1: Vcc
 CH2: V_{O+19V}
 CH3: Vcs
 CH4: I_{+19V}

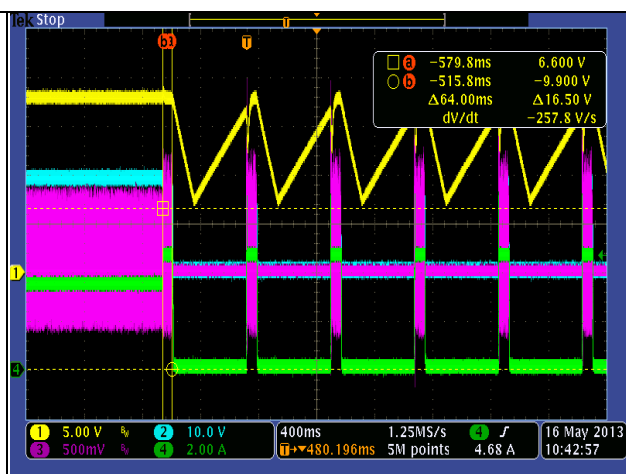

Fig.4

Over Current Protection
 Vin: 264Vac
 O/P : +19V=Max→OCP
 CH1: Vcc
 CH2: V_{O+19V}
 CH3: Vcs
 CH4: I_{+19V}

8. Over Voltage Protection

The supply shall be designed with appropriate output over voltage protection. This protection shall be activated in the event of a short or long-term condition during which one or more of the output open loop circuit happened. It shall limit the power supply without inflicting any damage to any internal supply components.

Test Condition:

Input: 90Vac/264Vac (60Hz)

Ambient Temperature: 25°C

Test Result: PASS

OVP by CS OVP		
	Primary-side	Second-side
Vin(Vac)	Vcc Voltage(V)	+19Vout(V)
Vac=90V	21.9	24.0
Vac=264V	22.4	24.4

Table 8

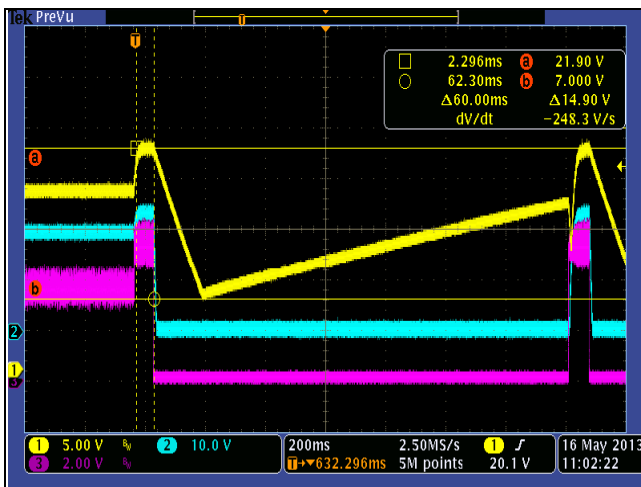

Over Voltage Protection Test

Fig.5

Vin: 90Vac turn on

O/P: +19V=3.42A

CH1: Vcc

CH2: V_{O+19V}

CH3: Comp

Reading: Vcc=21.9V (OVP Protection)

V_{O+19V} =24.0V

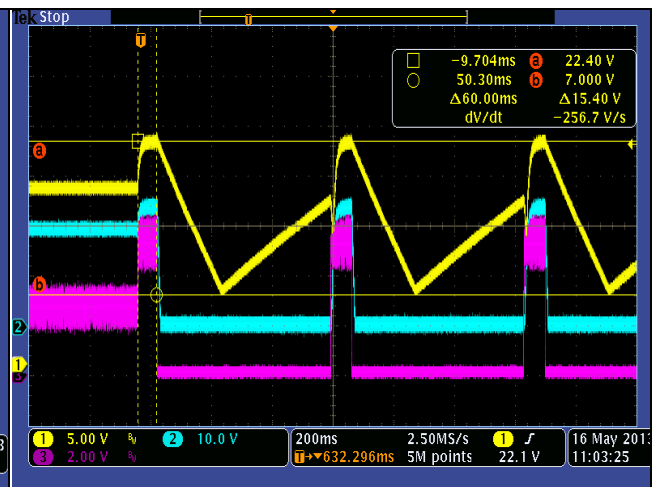

Over Voltage Protection Test

Fig.6

Vin: 264Vac turn on

O/P: +19V=3.42A

CH1: Vcc

CH2: V_{O+19V}

CH3: Comp

Reading: Vcc=22.4V (OVP Protection)

V_{O+19V} =24.4V

9. Output Short Protection

The supply shall be designed with appropriate output short circuit protection. This protection shall be activated in the event of a short or long-term condition happened. The primary shall limit the total power without inflicting any damage to any internal supply components and shall be reversible pending removal of the cause of the condition and without any user intervention.

Test Condition:

Input: 90Vac/264Vac (60Hz)

Ambient Temperature: 25°C

Test Result: PASS

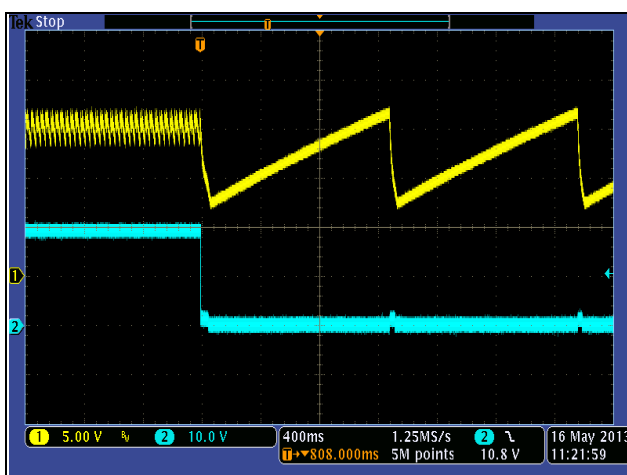

Output Short Protection
 Vin: 90Vac
 O/P : +19V=0A→Short
 CH1: Vcc CH2: V_{O+19V}

Fig.7

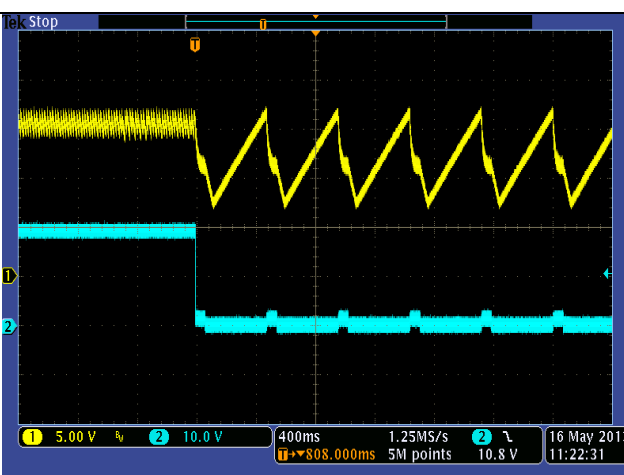

Output Short Protection
 Vin: 264Vac
 O/P : +19V=0A→Short
 CH1: Vcc CH2: V_{O+19V}

Fig.8

10. Efficiency Test

The efficiency of power supply shall be measured throughout its specified operating input range and at output maximum load conditions. It should meet Energy Star V2.0 Efficiency Level V.

Test Condition:

Input: 115Vac/230Vac (60Hz)

Output: 25%、50%、75%、100% of Max Load (3.42A)

Ambient Temperature: 25°C

	115V			230V	
Po	Pin	Eff(%)	Po	Pin	Eff(%)
65.01	73.13	88.89%	64.93	71.7	90.56%
48.62	54.38	89.41%	48.61	53.68	90.56%
32.43	35.89	90.30%	32.41	35.68	90.84%
16.17	17.8	90.84%	16.16	17.83	90.63%
Result		89.86%	Result		90.65%

Table 9

11. Power Component Stress Voltage
Test Condition:

- Set the output loads at full load and ambient 25 °C.
- The PSU test on everyone voltage and frequency.

Check:

- Under Steady state the derating shall be below **95%**.
- Under Transient state the derating shall be below **95%**.
- Input line bulk capacitors limits are **100%** (continuous).

Result:
Input Voltage: 90Vac/264Vac (60Hz)

Output Power: Max Load/Start-up Transient

No.	Location	Max. Rating(V)	Steady State(90V / 60HZ)	
			Measurement	Derating(%)
			V	V
1	D002	1000	54.4	5.44%
2	Q001	600	304	50.67%
3	D101	150	64	42.67%
4	C103	35	19.6	56.00%

Table 10-1

No.	Location	Max. Rating(V)	Steady State(264V / 60HZ)	
			Measurement	Derating(%)
			V	V
1	D002	1000	111	11.10%
2	Q001	600	552	92.00%
3	D101	150	105	70.00%
4	C103	35	19.6	56.00%

Table 10-2

No.	Location	Max. Rating(V)	Transient State(90V / 60HZ)	
			Measurement	Derating(%)
			V	V
1	D002	1000	55	5.50%
2	Q001	600	300	50.00%
3	D101	150	61.6	41.07%
4	C103	35	19.6	56.00%

Table 11-1

No.	Location	Max. Rating(V)	Transient State(264V / 60HZ)	
			Measurement	Derating(%)
			V	V
1	D002	1000	109	10.90%
2	Q001	600	556	92.67%
3	D101	150	104	69.33%
4	C103	35	19.6	56.00%

Table 11-2

12. Thermal Test
Test Condition:

- Set the output loads at full load and ambient **25°C**.
- The PSU test on everyone voltage and frequency.
- Born-In 2 hours

Check:

- All of component and magnetic device (transformer, Filter choke) shall NOT exceed 100°C.

Result:

No.	Location	Max. Rating(°C.)	90V/60Hz(°C.)	264/60Hz(°C.)	Derating(%)	
					90V/60Hz	264/60Hz
1	R011	125	84.8	70.3	67.84%	56.24%
2	D007	150	87.5	68.9	58.33%	45.93%
3	Q001	150	80	71	53.33%	47.33%
4	R019	125	86.9	63.9	69.52%	51.12%
5	IC001	150	68.7	57.5	45.80%	38.33%
6	D101	150	98.6	89.7	65.73%	59.80%
7	D001	150	84.7	55.1	56.47%	36.73%
Ambient					--	--

Table 12 Key Parts for Thermal Test

IV. Gerber File:

Silkscreen TOP

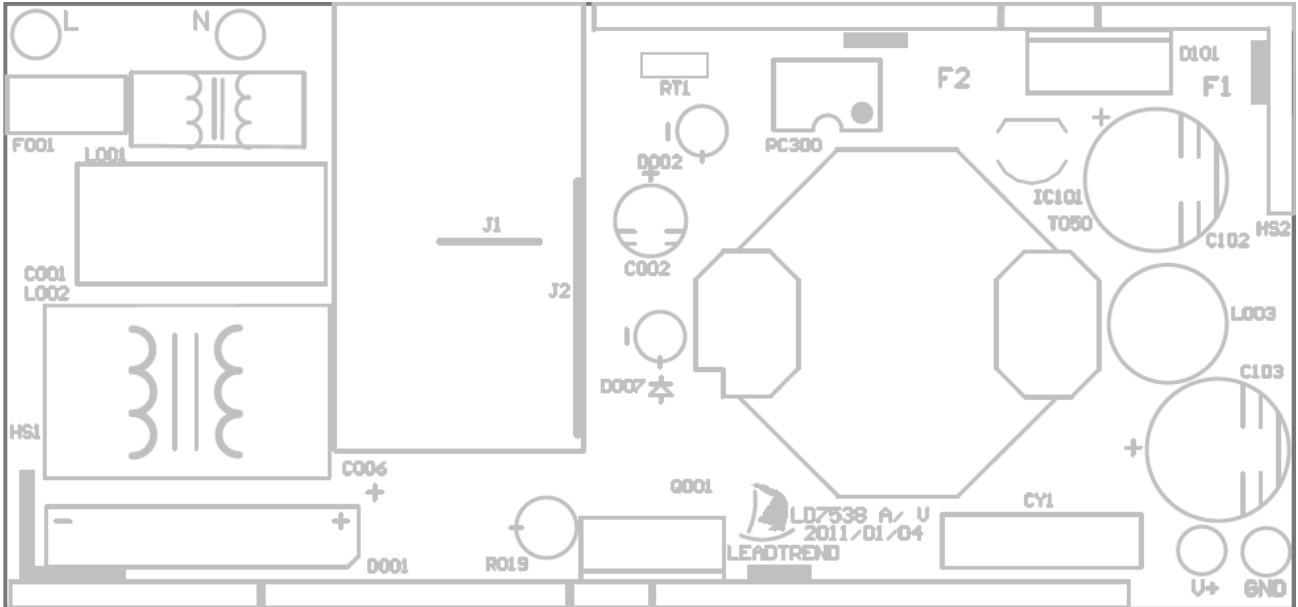

Silkscreen Bottom

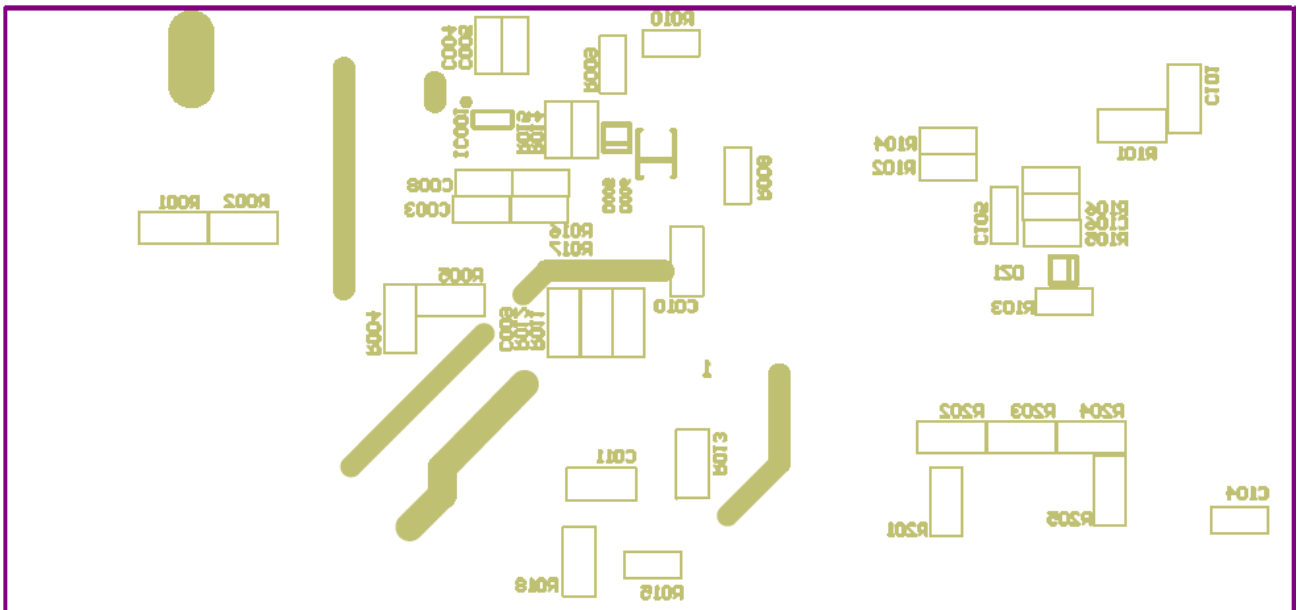

Bottom Layer

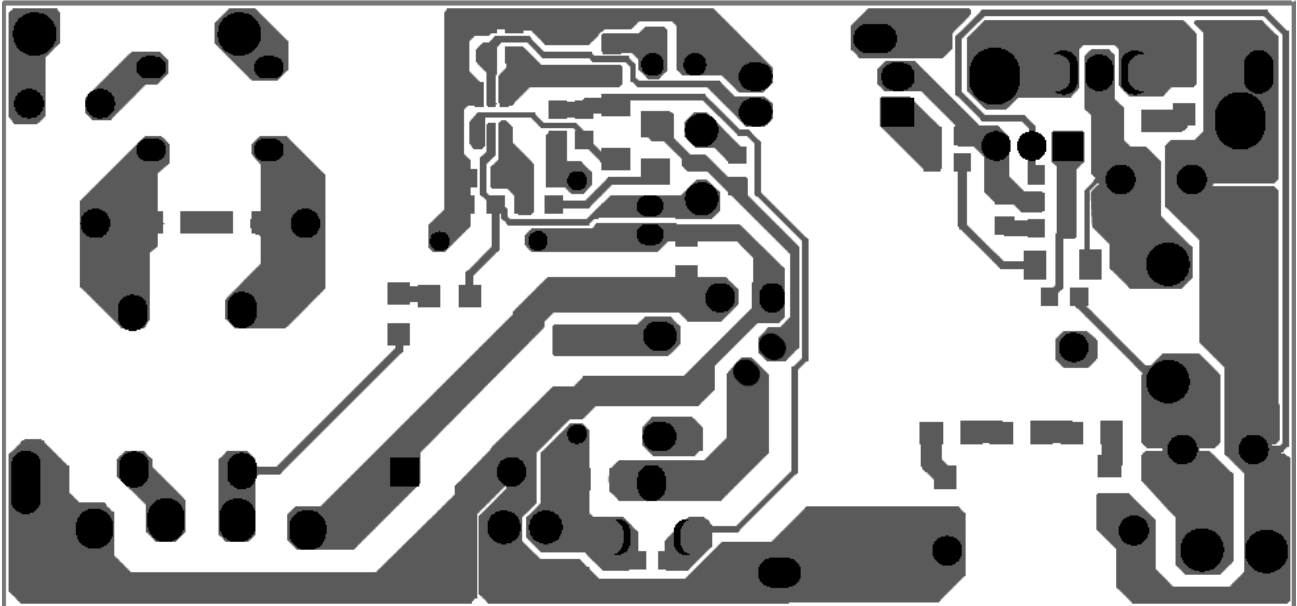

Soldermask Bottom

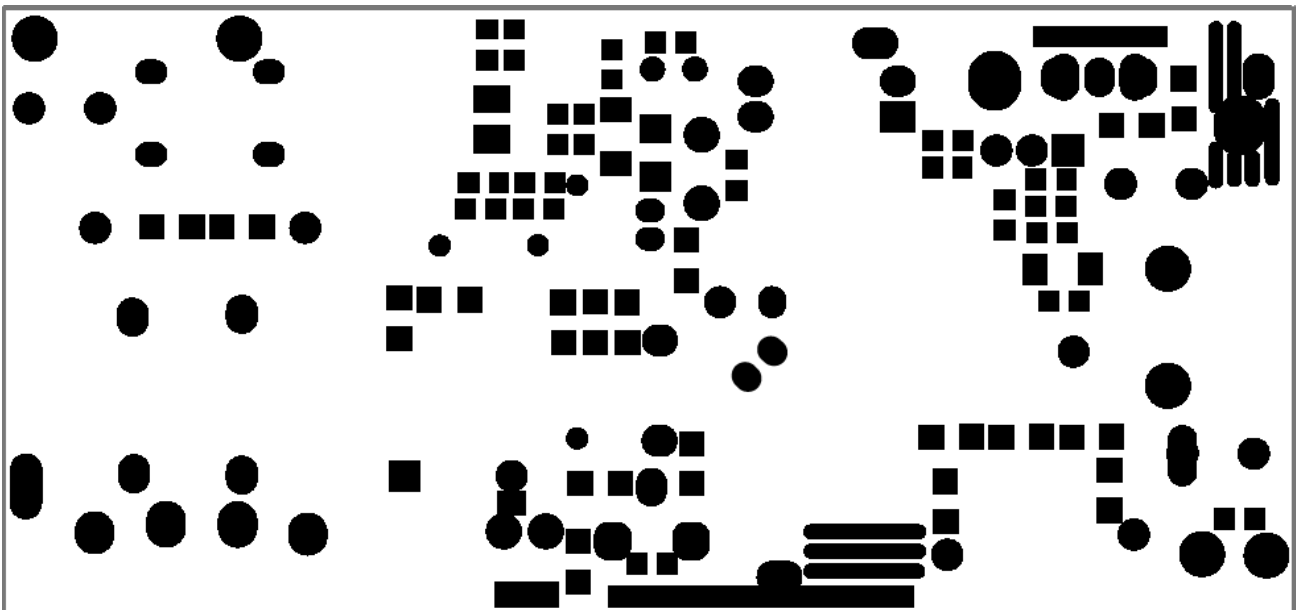

V. Transformer Specification:

Core: RM10 PC44 or 3C94

Bobbin: RM10

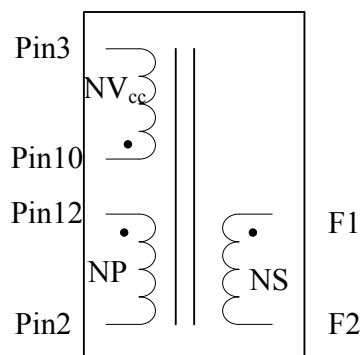
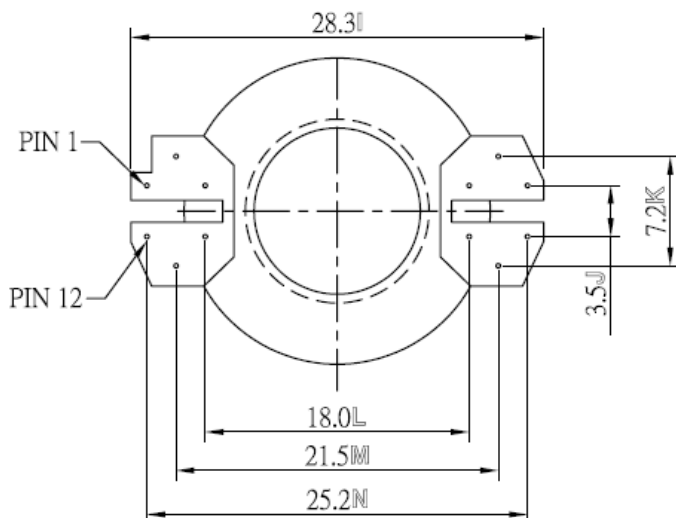

L, Pin12-2: 502uH±5%

Gap:以實測電感作調整

Np/Ns/NV_{cc}: 43/9/8

F1 上方出線長 50mm 含 5mm 鍍錫 and F2 上方出線 長 30mm 含 5mm 鍍錫

F1 加黑色套管

HI-POT: 3000V_{AC}: Primary to Secondary

1	0.3*3 (2-UEW) 22Ts PIN2 → PIN 1	2 Layers
2	3M#1350 1Ts	
3	銅箔 1Ts→PIN10	
4	3M#1350 1Ts	
5	0.65mm*2 (三層絕緣線) 9Ts F2(白) →F1(黑)	2 Layers
6	3M#1350 1Ts	
7	銅箔 1Ts→PIN10	
8	3M#1350 1Ts	
9	0.3*3 (2-UEW) 21Ts PIN1 → PIN 12	2 Layers
10	3M#1350 1Ts	
11	0.2mm*4(2-UEW) 8Ts PIN 3 → PIN10	平均疏繞
12	3M#1350 2Ts	
FINISHED		